

ASSEMBLY INSTRUCTIONS

HAPSBURG TABLE SET



PLEASE READ THESE STEPS BEFORE PROCEEDING

Included with your Hapsburg Table Set is the Following Hardware:

- Forty-four (44) 1/2" Stainless Steel Flat Washers
- Twenty-two (22) 1/2" Stainless Steel Hex Head Nuts
- Twenty-two (22) 1/2" Stainless Steel Lock Washers
- Two (2) 1/2" x 4" Stainless Steel Hex Head Cap Screws
- Twenty (20) 1/2" x 1 1/2" Stainless Steel Hex Head Cap Screws
- Four (4) 3/8" Stainless Steel Flat Washers
- Four (4) 3/8" x 1" Stainless Steel Hex Head Cap Screws

ABIDE BY THE FOLLOWING INSTALLATION INSTRUCTIONS

Brace

1. Place brace with angles across from each other.
2. Then align the brace with the holes with the holes in the angles of the other brace.
3. Place a 1/2" flat washer on a 1/2" x 4" cap screw and insert it through the holes in both braces.
4. Place 1/2" flat washer over threaded end of cap screw, then add 1/2" lock washer and nut. Do NOT tighten on this step.

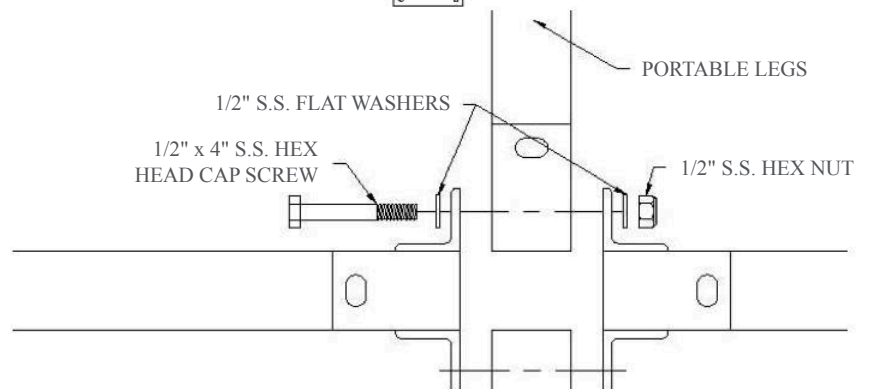
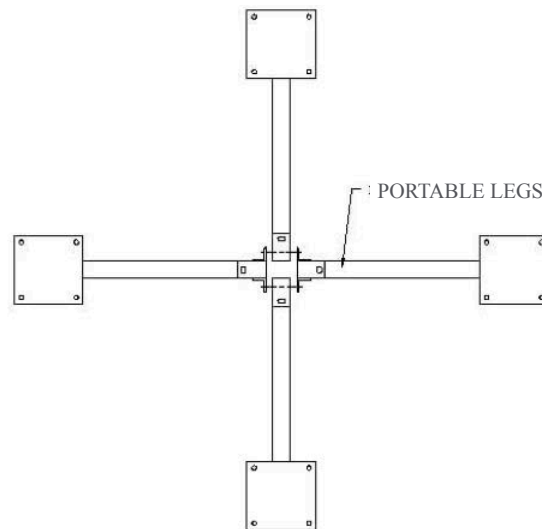

ASSEMBLY INSTRUCTIONS (con't)

HAPSBURG TABLE SET

Legs to Table Plate

1. Place table plate on pedestal, aligning the holes on the table plate with the holes on the pedestal.
2. Add 1/2" flat washer to 1/2" x 1 1/2" cap screw and insert down through the hole in the table plate and pedestal/legs.
3. Slide 1/2" flat washer over exposed threads and add 1/2" lock washer and nut and tighten.
4. After tightening table plate down, tighten brace screws.

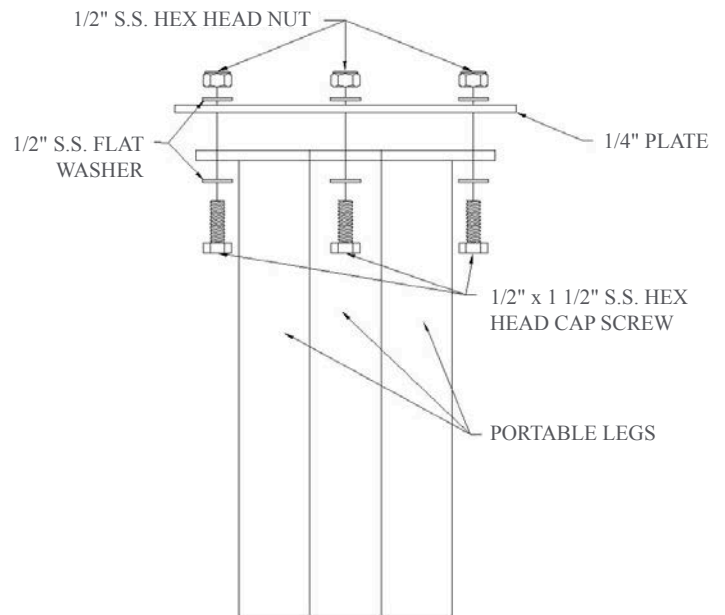

Legs / Table Plate Assembly to Table Top

1. Place table top over leg/table plate assembly, making sure to align the holes in the table mounting plate with the coupling nuts under the table.
2. Place 3/8" flat washer over 3/8" x 1" hex head cap screw and insert up through holes in mounting plate and thread into coupling nuts.
3. Tighten hex head cap screws into coupling nuts under table.

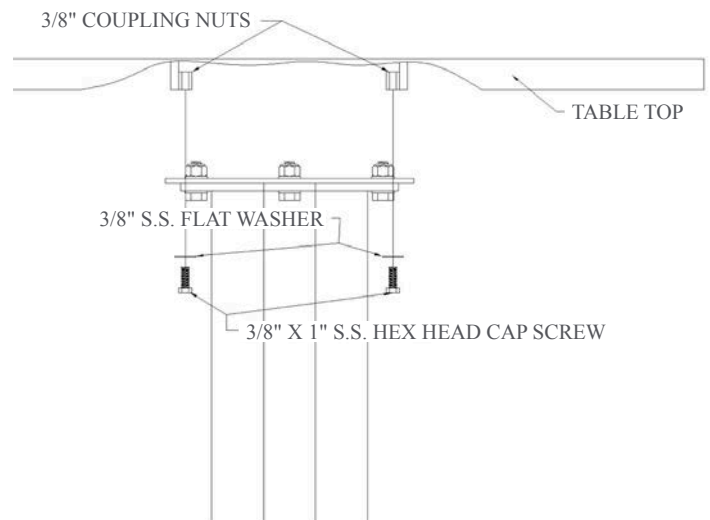

ASSEMBLY INSTRUCTIONS (con't)

HAPSBURG TABLE SET

Seat

1. Place seat on top of pedestal, matching up holes.
2. Add 1/2" flat washer to 1/2" x 1 1/2" cap screw and insert through holes in seat and pedestal.
3. Slide 1/2" flat washer over exposed threads and add 1/2" lock washer and nut and tighten.

