

ASSEMBLY INSTRUCTIONS

EASTON 6-SEAT TABLE SET



PLEASE READ THESE STEPS BEFORE PROCEEDING

Included with your Easton 6-Seat Table Set is the Following Hardware:

- Sixty-four (64) 1/2" Stainless Steel Flat Washers
- Thirty (30) 1/2" Stainless Steel Hex Head Nuts
- Thirty (30) 1/2" Stainless Steel Hex Lock Washer
- Thirty (30) 1/2" x 1 1/2" Stainless Steel Hex Head Cap Screws
- Four (4) 3/8" X 1" Stainless Steel Hex Head Cap Screws
- Twelve (16) 3/8" Stainless Steel Flat Washers
- Six (6) 3/8" x 2" Stainless Steel Hex Head Cap Screws
- Six (6) 3/8" Stainless Steel Lock Washers
- Six (6) 3/8" Stainless Steel Hex Head Nuts

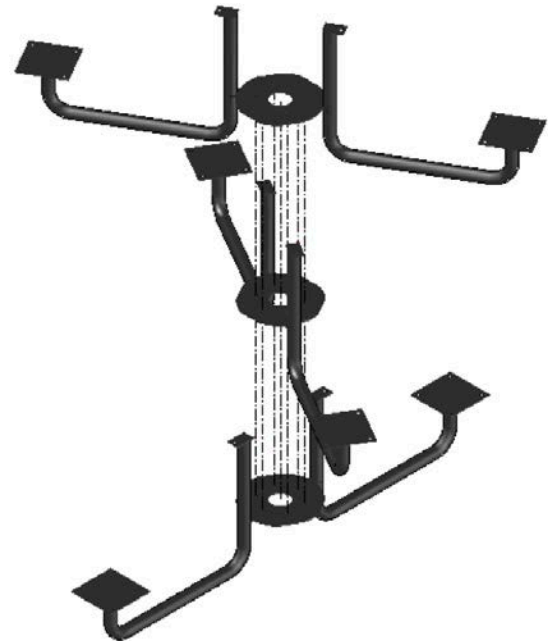

ABIDE BY THE FOLLOWING INSTALLATION INSTRUCTIONS

Braces

1. Place braces so plates are approx 60 degrees from each other.
2. Legs are labeled (B) for bottom, (M) for middle, and (T) for top.
3. Pick up the brace with marked (M) and place it on top of brace marked (B). Pick up plate marked (T) and place it on top of subassembly making sure that the holes in the hubs line up.
4. Place a 3/8" washer on a 3/8" x 2" cap screw and insert it through the holes in the hubs.
5. Place 3/8" washer and 3/8" lock washer over threaded end of cap screw, then add 3/8" nut. Only hand tighten nuts and bolts on this step.

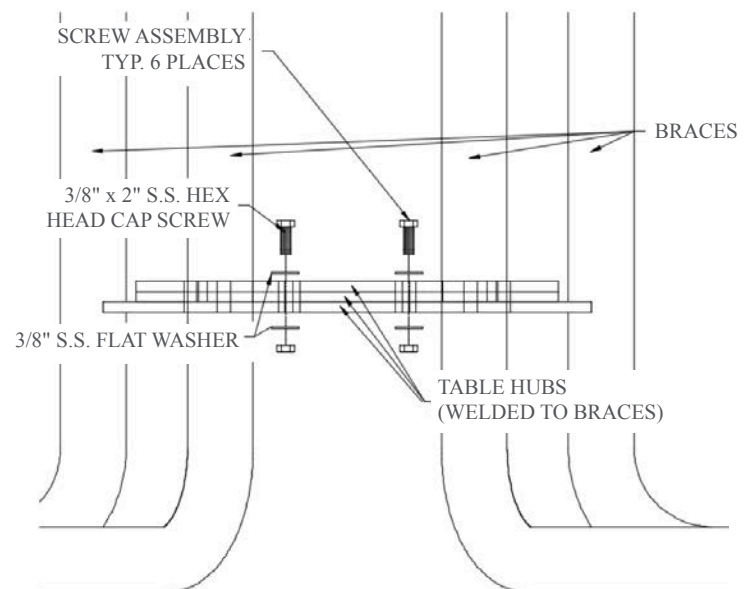

ASSEMBLY INSTRUCTIONS (con't)

EASTON 6-SEAT TABLE SET

Legs to Table Plate

1. Place table plate on pedestal, aligning the holes on the table plate with the holes on the pedestal.
2. Add 1/2" washer to 1/2" x 1 1/2" cap screw and insert down through the hole in the table plate and pedestal/legs.
3. Slide 1/2" washer and 1/2" lock washer over exposed threads and add 1/2" nut and tighten.
4. After tightening table plate down, tighten brace screws.

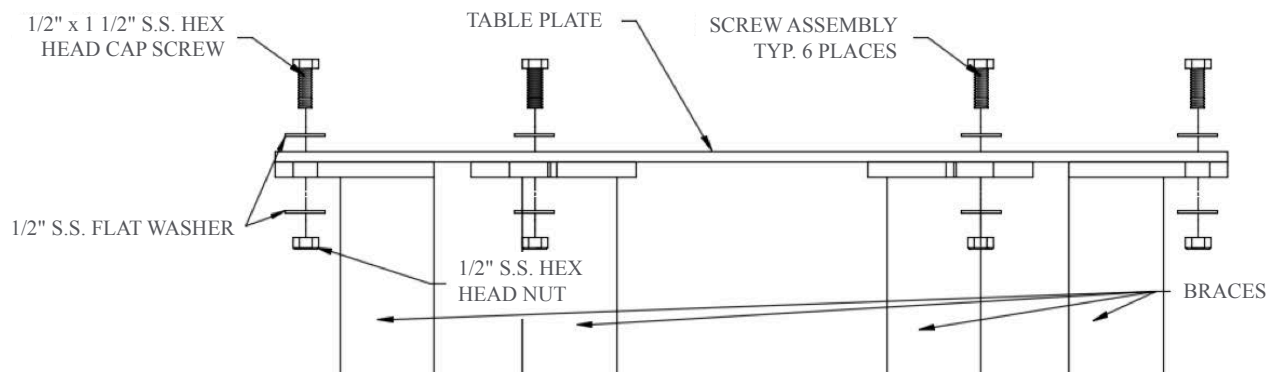
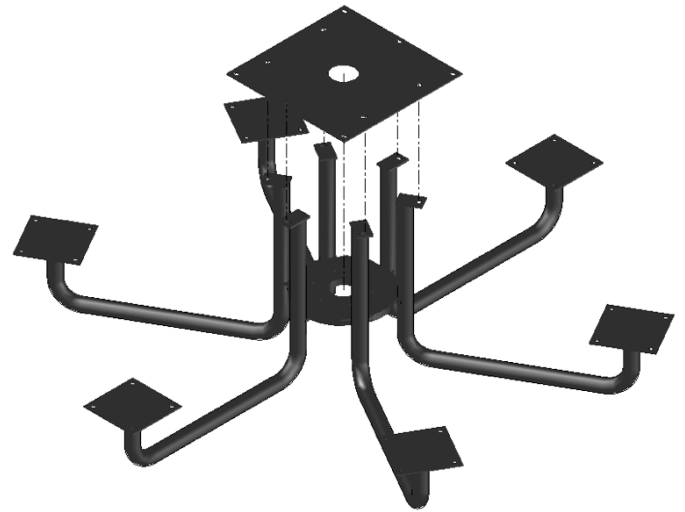

Legs / Table Plate Assembly to Table Top

1. Place table top over leg/table plate assembly, making sure to align the holes in the table mounting plate with the nuts under the table.
2. Place 3/8" flat washer over 3/8" x 1" hex head cap screw and insert up through holes in mounting plate and thread into nuts.
3. Tighten hex head cap screws into nuts under table.
(Shown upside down and without legs for clarity.)

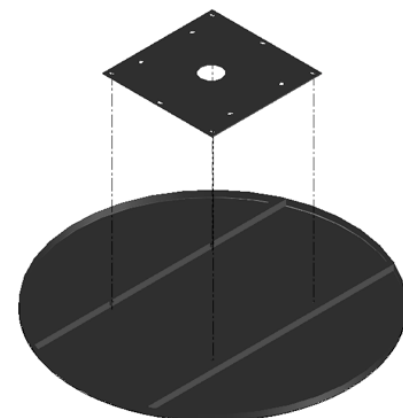

ASSEMBLY INSTRUCTIONS (con't)

EASTON 6-SEAT TABLE SET

Seat

1. Place seat on top of pedestal, matching up holes.
2. Add 1/2" washer to 1/2" x 1 1/2" cap screw and insert through holes in seat and pedestal.
3. Slide 1/2" washer and 1/2" lock washer over exposed threads and add 1/2" nut and tighten.

After all parts are assembled, tighten all nuts and bolts.

